

G1109 90° Peel Fixture - Installation Instructions

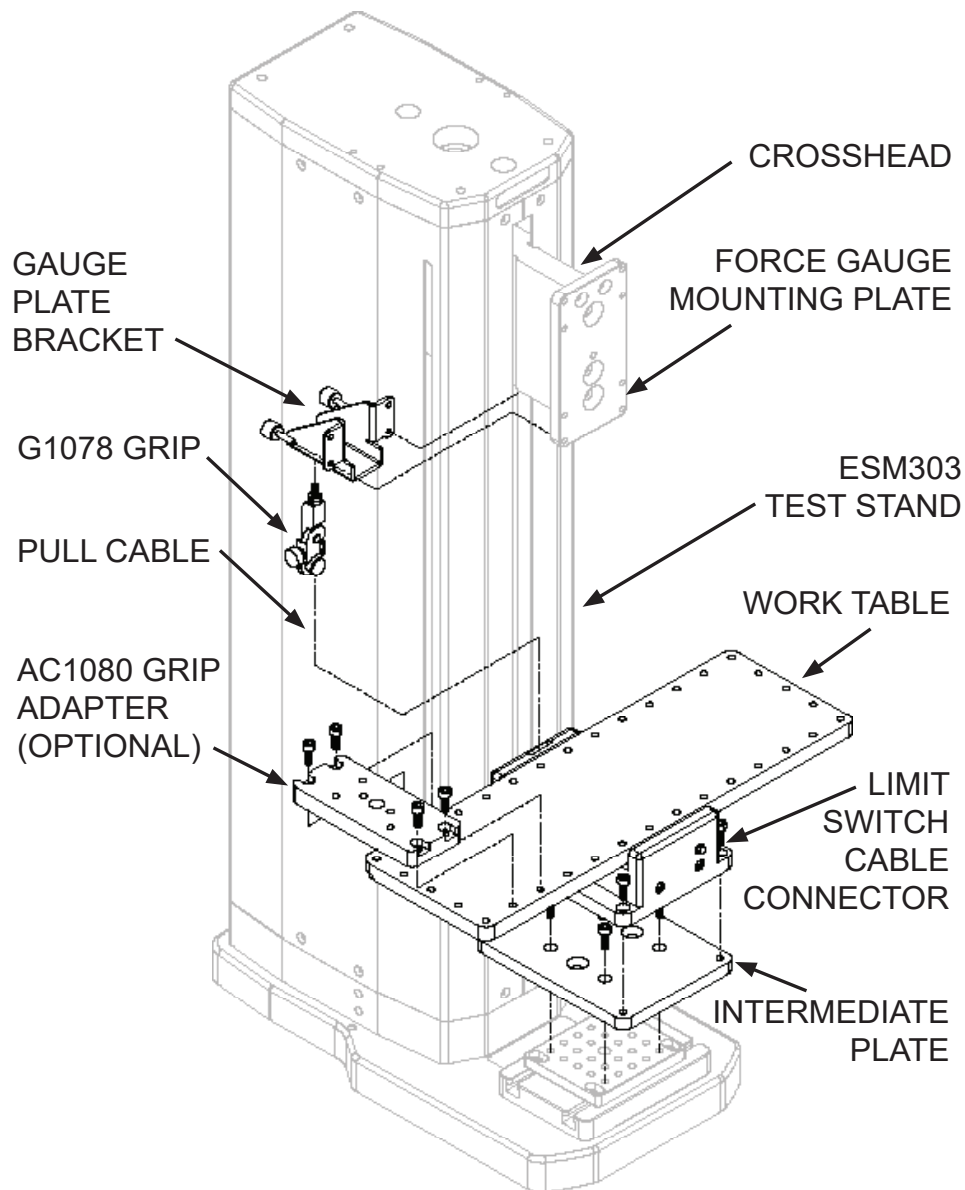

The G1109 90° peel fixture mounts to the following Mark-10 test stands and frames: ESM303, F105, F305, F505. The illustration at left depicts proper installation. Please follow these instructions:

ESM303 only

1. Mount the intermediate plate to the base plate of the test stand with four socket head screws.
2. Mount the fixture onto the intermediate plate with four socket head screws.
3. Install a force gauge onto the force gauge mounting plate using only the upper two thumb screws, provided with the ESM303.
4. Install the G1078 grip onto the gauge plate bracket.
5. Attach the gauge plate bracket to the back of the force gauge mounting plate by installing the two provided thumb screws through the corresponding clearance holes, into the threaded holes in the force gauge housing.
6. Position the crosshead at an appropriate starting position for the test.
7. Pull the loose end of the pull cable from the rear of the fixture until the work table has reached the end of its leftward travel.
8. *Consider asking for the assistance of a colleague with this step.* While holding the work table in place at its end of travel, wrap the pull cable at least three times around the bollard on the G1078 grip, then route the cable through the slot and tighten with the thumb screw.
9. If the optional AC1080 grip adapter is required, install it to the work table with four socket head screws.
10. *This step is not necessary, but is recommended to protect the pull cable.* Connect the limit switch cable from the connector on the right side to the connector at the rear of the test stand labeled "AUX. LIMITS". When the work table reaches the end of travel, the test stand will stop and the indicator in front of the fixture will illuminate.



For Series F test frames, skip steps 3, 4, and 5. Mount the G1078 grip to the threaded hole on the underside of the Series F crosshead (use the hole on the right when facing the front of the test stand).

If using the optional AC1078 or AC1079 adjustable angle adapter, refer to the installation instructions on Page 2.

G1109 90° Peel Fixture

AC1078 & AC1079 Angle Adapters (optional) - Installation Instructions

AC1078

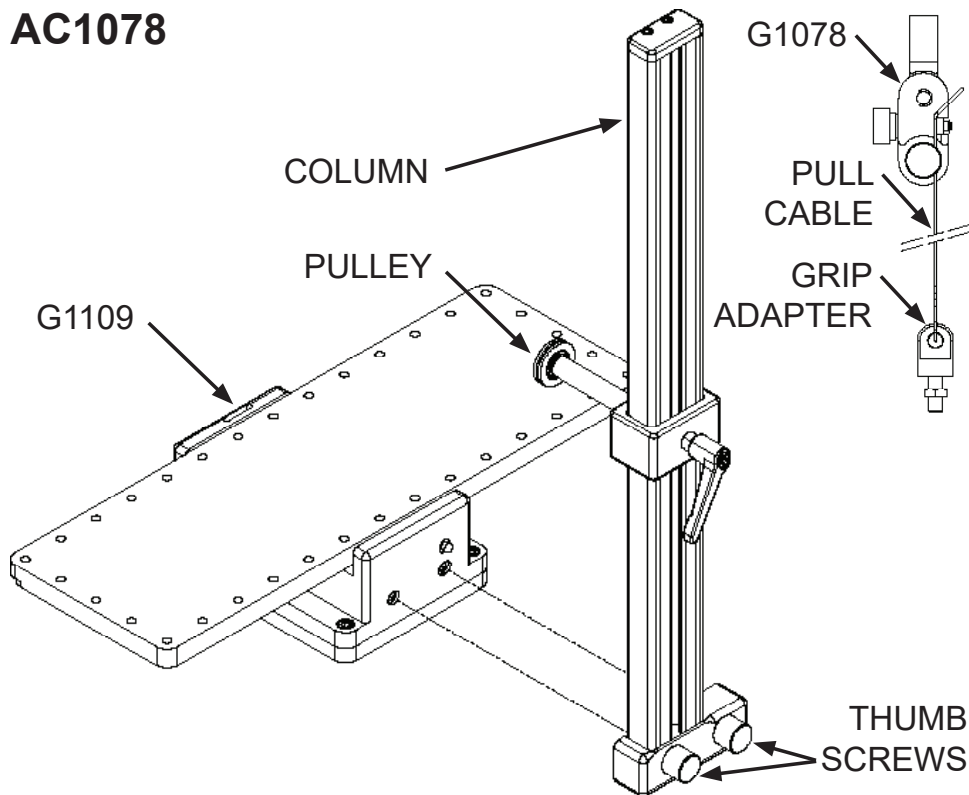

1. Install the G1109 fixture to the test stand, as described on Page 1.
2. Install the column to the base of the G1109 with two thumb screws.
3. Tie a loop with the pull cable through the hole in the grip adapter, then fasten the desired grip to the adapter.
4. Install the G1078 miniature bollard grip to the force gauge or sensor, then wrap and secure the pull cable as described on Page 1.
5. When setting up the sample, adjust the pulley height as needed, and route the pull cable around the pulley.

AC1079

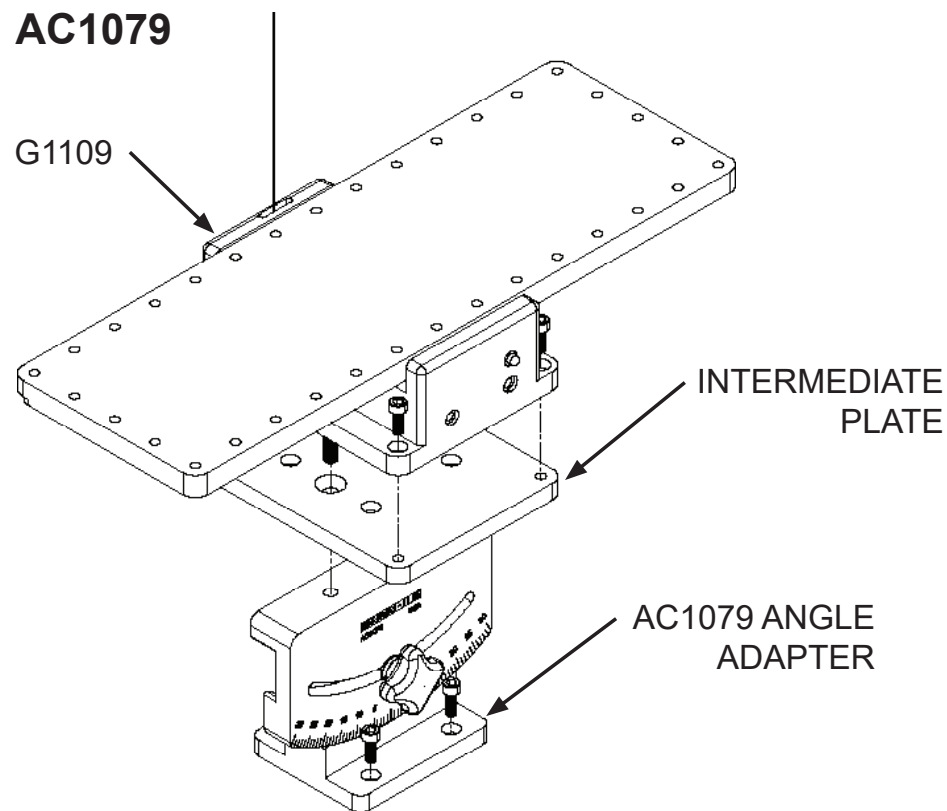

1. Install AC1079 to the base plate of the test stand using four socket head screws.
2. Install the intermediate plate onto AC1079 using two flat head screws.
3. Install G1109 to the adapter plate using four socket head screws.