

Force Test Stand Model **ESM301 / ESM301L**

---

# **User's Guide**

**MARK-10**<sup>®</sup>

## Thank you...



Thank you for purchasing a Mark-10 ESM301 / ESM301L Force Test Stand, designed for producing up to 300 lbf (1.5 kN) of tension or compression force. The ESM301 is an essential component of a force testing system, typically also comprising a force gauge and grips.

With proper usage, we are confident that you will get many years of great service with this product. Mark-10 test stands are ruggedly built for many years of service in laboratory and industrial environments.

This User's Guide provides setup, safety, and operation instructions. Dimensions and specifications are also provided. For additional information or answers to your questions, please do not hesitate to contact us. Our technical support and engineering teams are eager to assist you.

**Before use, each person who is to use the test stand should be fully trained in appropriate operation and safety procedures.**

## TABLE OF CONTENTS

OVERVIEW .....	3
SETUP AND SAFETY .....	4
OPERATION BASICS .....	6
TEST FEATURE SETUP .....	8
OPERATING MODES .....	18
COMMUNICATION .....	23
FUNCTION ACTIVATION .....	25
TROUBLESHOOTING .....	27
MAINTENANCE AND SERVICE .....	28
SPECIFICATIONS .....	29
DIMENSIONS .....	29

## 1 OVERVIEW

### 1.1 List of included items

Qty.	Description
1	ESM301 or ESM301L test stand
4	Force gauge mounting thumbscrews
2	Limit switch thumbscrews (same as above, supplied in a separate package)
1	Power cord
1	Cable, controller to test frame 12" (longer cables are optional)
1	Cable, USB to RJ11 (for travel indication option)
1	ESM301-002-X column extension (optional)
1	ESM301-003 bench mounting kit (optional)
1	09-1162 multi-function cable (optional)
1	09-1056 serial cable (optional)
1	RSU100 USB converter (optional)
1	Accessories kit (small hook, medium hook, 2" diameter compression plate, 2" extension rod, #10-32 coupler, Allen wrench set)
1	Resource CD

**Note:** Unless otherwise indicated, all references to the model ESM301 also apply to the ESM301L.

### 1.2 Physical Features

Note the following physical features of the ESM301. The user's guide will reference this terminology.

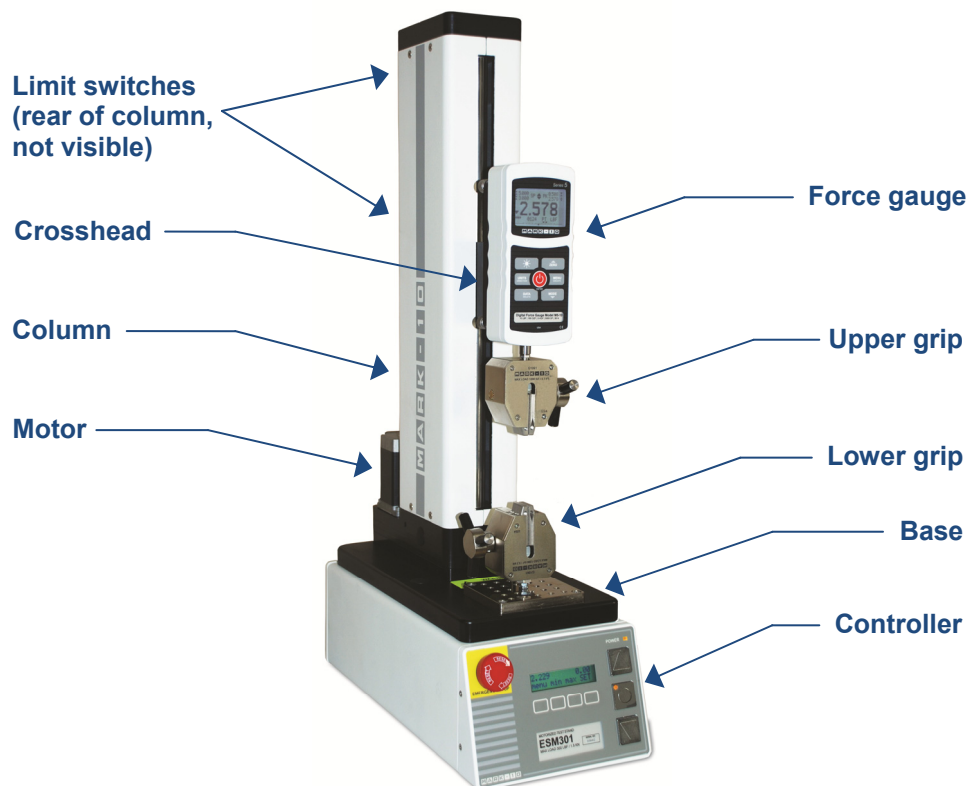

## 2 SETUP AND SAFETY

### 2.1 Mounting

Place the stand on a clean, flat and level work area free from vibration. If desired, the stand can be secured to the work area with 1/4-20 screws fastened into the underside of the base. Failure to properly mount the test stand may make it more vulnerable to tipping, causing a hazardous situation.



**IMPORTANT: Do not fasten any screws more than 0.25 in [6 mm] into the base of the test stand, or damage to internal components can occur.**

The test stand can also be mounted using the ESM301-003 mounting kit. Screws of various lengths are supplied with this kit to accommodate a range of bench thicknesses. Refer to the illustration below for proper assembly:

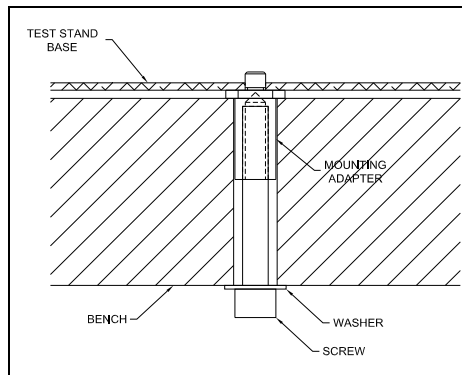

In general, the ESM301 can be mounted at any angle, although extra care should be taken during installation and operation.

When the test stand is in a stable and secure position, install a force gauge with four thumb screws (provided). Mark-10 gauges mount directly without adapters. Grips can be mounted onto the force gauge and test stand base.

### 2.2 Installing the limit switches

Upper and lower limit switches are provided to stop crosshead travel at user-designated positions. Each limit switch consists of an internal block riding along a rail, and an external thumbscrew. The thumbscrews are shipped in a separate bag to avoid damage in transit. Refer to the illustration below for proper installation:

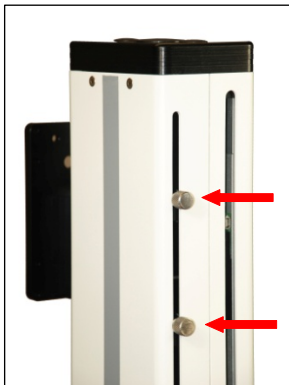

### 2.3 Connections and Outputs

The power plug and controller cable must be connected to the rear of the controller, as shown in the illustration below:

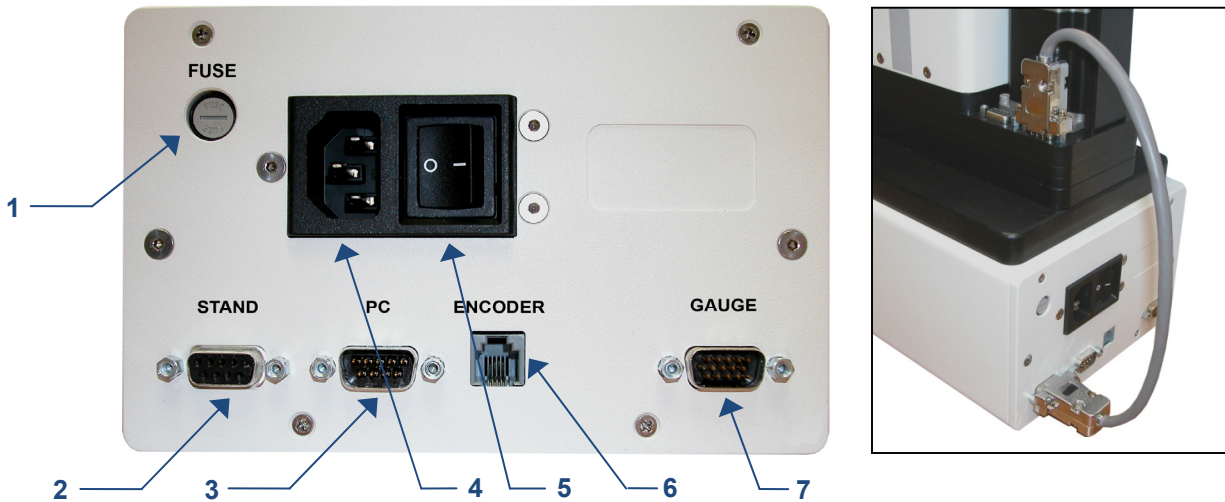

**1. Fuse**

**2. Controller Cable Connector**

Plug one end of the cable into this connector, and the other end into the connector as shown in the illustration on the right.

**3. RS-232 Connector**

Outputs force only or force and travel data via RS-232. Also allows for PC control, if appropriate functions are enabled. Plug one end of the 09-1056 serial cable into this connector, and the other end into a serial connector on a computer or USB converter.

**4. Power Plug Receptacle**

Plug the power cord in here. Refer to the **Connecting Power** sub-section for important safety information.

**5. Power switch.**

**6. Travel Indication Connector**

Plug one end of the USB/RJ11 cable into this connector, and the other end into the mini USB connector in the rear of the crosshead.

**7. Force Gauge Cable Connector**

Interfaces with a Series 7, 5 or 4 force gauge. Plug one end of the 09-1162 cable into this connector, and the other end into the gauge.

### 2.4 Safety / proper usage

Typical materials able to be tested by the ESM301 include many manufactured items, such as springs, electronic components, fasteners, caps, films, mechanical assemblies, and many others. Items that should not be used with the ESM301 include potentially flammable substances or products, items that can shatter in an unsafe manner, and any other components that can present an exceedingly hazardous situation when acted upon by a force.

### 2.4.1 Using Grips & Fixtures with the ESM301

Ensure that the grip or fixture is positioned to ensure axial load with respect to the loading shaft of the force gauge. When using a grip, ensure that it secures the sample in such a way that it is prevented from slipping out during a test, preventing a potential safety risk to the operator and others in the vicinity. If using a grip or fixture from a supplier other than Mark-10, ensure that it is constructed of suitably rugged materials and components.

## 2.5 Connecting power

Plug one end of the power cord into its receptacle at the rear of the stand and the other end into a wall outlet with local earth ground (3-prong connector).

Before turning on power, the following safety checks and procedures should be performed:

1. Never operate the test stand if there is any visible damage to the power cord or the test stand itself. The ESM301 is powered by 110V/220V. Any contact with this high voltage can cause serious injury or even death.
2. Ensure that the test stand is kept away from water or any electrically conductive liquids at all times.
3. Make sure the electrical outlet powering the test stand has local earth ground (3-prong connector).
4. The test stand should be serviced by a trained technician only. Power must be disconnected before the column covers are removed.

After the above safety checks and procedures have been performed, the test stand may be powered on and is ready for operation.

## 3 OPERATION BASICS

### 3.1 Operational Safety

The following safety checks and procedures should be performed before and during operation:

1. Always consider the characteristics of the sample being tested before initiating a test. A risk assessment should be carried out beforehand to ensure that all safety measures have been addressed and implemented.
2. Wear eye and face protection when testing, especially when testing brittle samples that have the potential to shatter under force. Be aware of the dangers posed by potential energy that can accumulate in the sample during testing. Extra bodily protection should be worn if a destructive failure of a test sample is possible.
3. Keep away from moving parts of the test stand. Loose articles of clothing should not be worn. Long hair should be covered to avoid a hazardous situation. A Crush Hazard warning label is located on the base of the test stand. It appears as follows:



**Definition:** Keep any body parts and clothing clear of the area between the base of the test stand and the moving crosshead.

4. In those applications where samples can shatter, or other applications that could lead to a hazardous situation, use of a machine guard is strongly recommended.
5. When the test stand is not in use, ensure that the power is turned off to prevent accidental engagement of any of the controls.

### 3.2 Controls

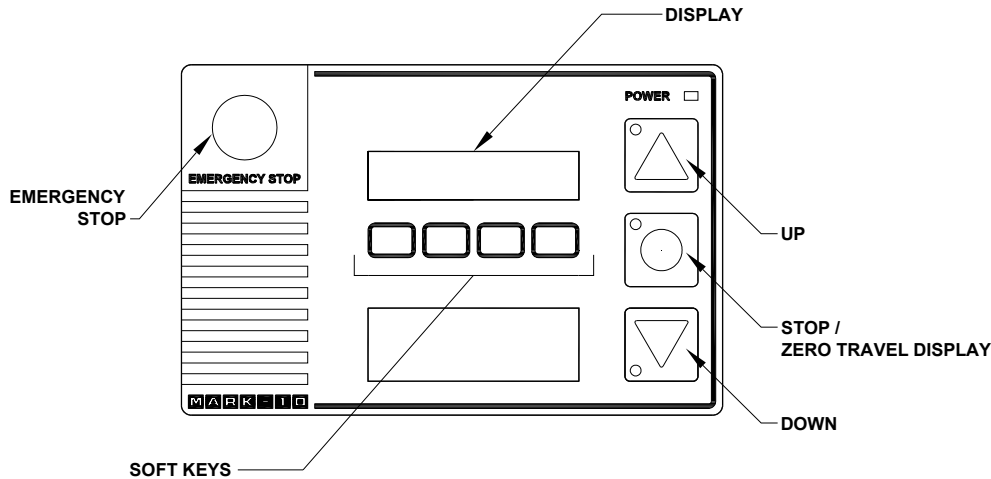

Key	Primary Function
<b>SOFT KEYS</b>	Functions are determined by the corresponding text on the display.
<b>UP</b>	Commences movement in the up direction.
<b>DOWN</b>	Commences movement in the down direction.
<b>STOP / ZERO TRAVEL DISPLAY</b>	Stops crosshead movement. Press and hold for two seconds to zero the travel display (if travel indication option is installed).
<b>EMERGENCY STOP</b>	Press this button anytime to stop test stand motion. Rotate clockwise to release.

### 3.3 Modes Overview

The ESM301 has three functional modes:

1. **OPERATING MODE**  
This is the operating mode in which testing sequences can be started and stopped.
2. **TEST FEATURE SETUP**  
In this mode, test features are configured, such as rate of speed, number of cycles, password editing, and other features.
3. **FUNCTION ACTIVATION**  
Many test stand functions, such as cycling, auto return, distance measurement, and others are ordered individually as options. The **Function Activation** menu provides a means of identifying which functions were purchased. Through this menu, it is also possible to enable any functions not originally purchased via an activation code. All functions are temporarily enabled for the first 160 hours of operation, as described below:

**DEMO MODE**

The ESM301 is shipped in *Demo Mode*, during which time all available functions are temporarily activated for 160 hours of operation. At power-up, a counter displays the number of hours remaining, as follows:



```

REMAINING DEMO
TIME: 160 HOURS
  
```

Press **STOP** to continue.

At the end of this period, any functions not originally purchased will be deactivated, and will no longer be accessible from the **Test Feature Setup** menu. *Demo Mode* can be suspended at any time by pressing and holding **STOP** while turning on power to the test stand. This mode can be re-enabled in the same manner, and will be active for the remaining time period.

Refer to the **Function Activation** section for instructions for field activation.

## 4 TEST FEATURE SETUP

This section provides configuration instructions for each test feature.

Feature	Standard / Optional
Speed (same for both directions)	Standard
Independent up and down speeds	Optional
Auto return	Optional
Cycling with dwell time	Optional
Programmable travel limits	Optional
Overload protection	Optional
Preload	Optional
Load Holding	Optional
Break Detection	Optional
PC control	Optional
Communication settings	Standard
Units of speed	Standard
Programmable button configuration	Standard
Password protection	Standard

All ESM301 test stands are shipped in *Demo Mode*, as explained in the **Overview** section. After *Demo Mode* expires, only installed functions will be displayed in **Test Feature Setup**. The initial Test Feature Setup screen appears as follows:

```

SPEED:      10.00
ESC  <-  ->  ENTR
  
```



Label	Description
ESC	Exits Test Feature Setup, reverts to Operating Mode
< -	Scrolls to the previous feature
- >	Scrolls to the next feature
ENTR	Selects the feature, allowing it to be modified

When the features have been configured as desired and are ready to be saved, press **ESC** to exit Test Feature Setup. The screen will show **SAVE CHANGES?** Pressing **YES** will save the changes and the display will revert to current status. Pressing **NO** will not save the changes and return to the Test Feature Setup menu.

**Note:** Changes can be made to an unlimited number of settings before saving.

The following is a flow chart for the menu structure:

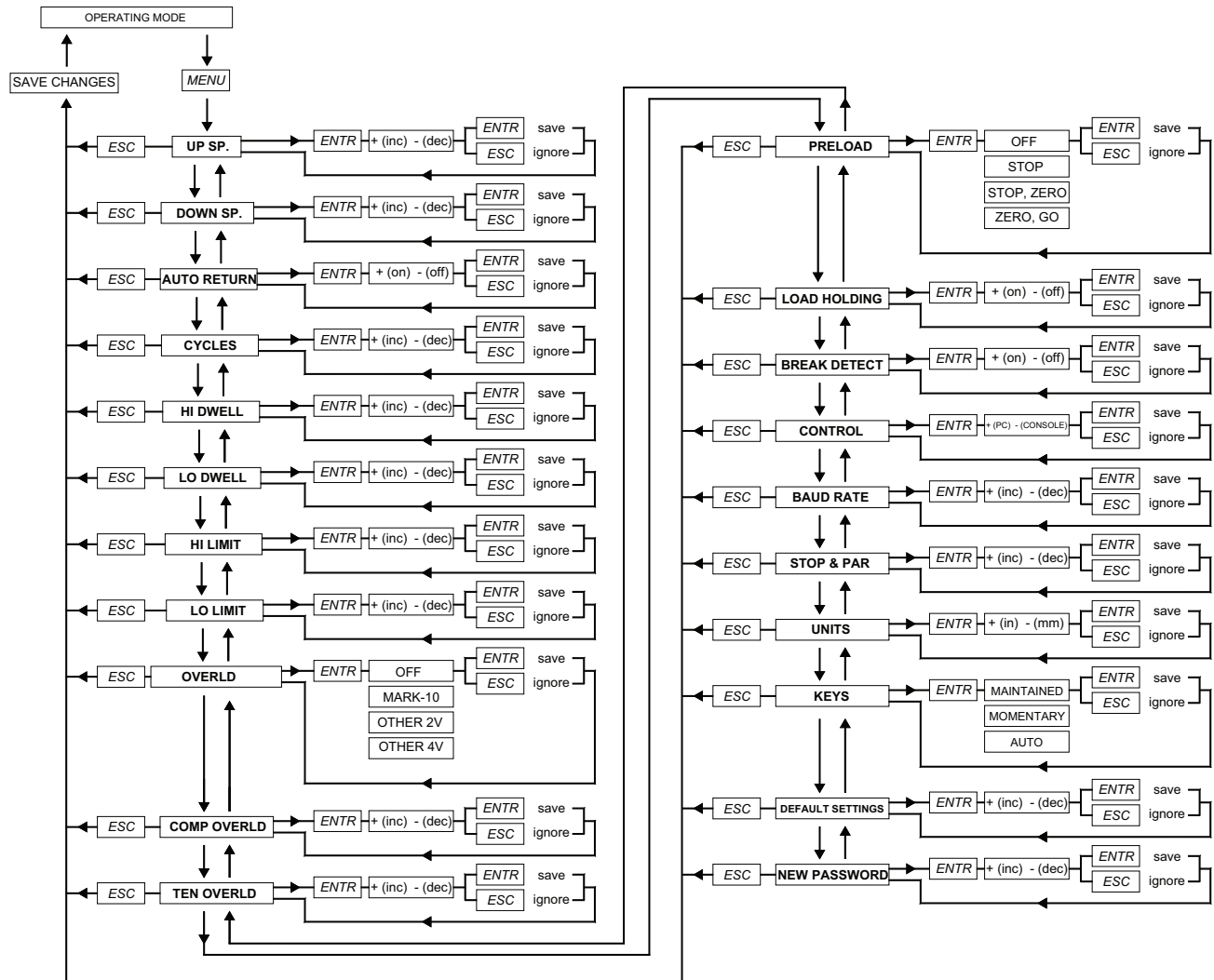

#### 4.1 Speed, Up Speed, Down Speed (SPEED, UP SPEED, DOWN SP)

If the independent up and down speed option has not been installed, the up and down speeds will be the same, and is programmed in the **SPEED** feature. If the independent up and down speed option is installed, **UP SPEED** and **DN SPEED** features will be present, and may be set individually.

*Default setting: 10 in/min*

*Available settings: 0.02 – 45 in/min*

```

UP SPEED : 10.73
ESC - + ENTR
  
```

Label	Description
+	Increments the speed setting by .01 in or .5 mm. Holding down + will increment at an increasingly faster rate.
-	Decrements the speed setting by .01 in or .5 mm. Holding down - will decrement at an increasingly faster rate.
ENTR	Returns to the Test Feature Setup menu
ESC	Exits the feature without saving changes

#### 4.2 Auto Return (AUTO RETURN)

With this function, the crosshead moves to a limit switch or *soft limit* (force set point, distance limit, preload, or break detection), whichever occurs first, and stops. Then, the crosshead returns to the other limit and stops. The test speed is dictated by the **SPEED** setting or the **UP SPEED** and **DOWN SP** settings. The return speed is always maximum speed. The maximum speed depends on whether or not the optional high speed range has been installed.

*Default setting: off*

*Available settings: off, on*

```

AUTO RETURN off
ESC - + ENTR
  
```

Label	Description
+ or -	Cycles through the available settings
ENTR	Returns to the Test Feature Setup menu
ESC	Exits the feature without saving changes

**Note:** If **AUTO RETURN** is turned **on**, **CYCLING** is automatically turned **off** and the **KEYS** feature is automatically set to **MAINTAINED** mode. See following pages for details on the **CYCLING** and **KEYS** features.

#### 4.3 Cycling (CYCLES)

This setting allows the user to configure the number of up and down cycles through which the crosshead will sequence. One cycle consists of the crosshead moving to a limit switch or *soft limit*, whichever occurs first, at the specified speed, stopping for the specified amount of dwell time, and returning to the other limit at the specified speed. If the independent up and down speed function is not enabled, the speed will be the same in both directions.

*Default setting: 00000 (off)*

*Available settings: 00000 – 99999*

```

CYCLES :    0 0 0 0 0
ESC   -   +   ENTR

```

Label	Description
+	Increases the number of cycles in increments of 1. Holding down + will increment at an increasingly faster rate. If 99999 is reached the next number will be 00000 and continue incrementing.
-	Decreases the number of cycles in increments of 1. Holding down - will decrement at an increasingly faster rate. If 00000 is reached the next number will be 99999 and continue decrementing.
<b>Press and hold + and - simultaneously</b>	If pressed and held for 2 seconds or longer the number of cycles will change to 0.
<b>ENTR</b>	Returns to the Test Feature Setup menu
<b>ESC</b>	Exits the feature without saving changes

#### 4.4 Upper and Lower Dwell Times (U DWELL and LO DWELL)

This setting corresponds to the amount of time, in seconds, for which the crosshead stops at the limit during a cycle sequence.

##### Note:

The dwell time setting is unavailable for an auto return sequence.

*Default setting: 0 (no dwell time)*

*Available settings: 0 – 9999.9*

```

HI DWELL :  0 0 0 0 . 0
ESC   -   +   ENTR

```

Label	Description
+	Increases dwell time in increments of .1. Holding down + will increment at an increasingly faster rate. If 9999.9 is reached the next number will be 0 and continue incrementing.
-	Decreases dwell time in increments of .1. Holding down - will decrement at an increasingly faster rate. If 0 is reached the next number will be 9999.9 and continue decrementing.
<b>ENTR</b>	Returns to the Test Feature Setup menu
<b>ESC</b>	Exits the feature without saving changes

#### 4.5 Upper and Lower Travel Limits (UPPER LM and LOWER LM)

This setting corresponds to the travel distance the crosshead moves before stopping or cycling. Upper and lower limits are programmed individually. The programmed distances are relative to the zero position of the crosshead. The travel indicator can be zeroed by pressing and holding **STOP** for 3 seconds.

*Default settings: +12.000 in, -12.000 in (ESM301) or +19.000 in., -19.000 in (ESM301L)*

*Available settings: From -19.000 to +19.000 in*

```

HI LIMIT :   2 . 0 5 8
ESC   -   +   ENTR

```

Label	Description
+	Increases the travel limit setting by .001 in or .02 mm. Holding down + will increment at an increasingly faster rate.
-	Decreases the travel limit setting by .001 in or .02 mm. Holding down - will increment at an increasingly faster rate.
ENTR	Returns to the Test Feature Setup menu
ESC	Exits the feature without saving changes

#### 4.6.1 Overload Protection (OVERLD)

The ESM301 protects a force gauge from overload by measuring incoming analog voltage and stopping crosshead travel when the programmed percentage of full scale has been reached. The default setting is for Mark-10 gauges ( $\pm 1V$ ), however, the setting may be changed to  $\pm 2V$  or  $\pm 4V$  to accommodate other force gauges.

*Default setting: OFF*

*Available settings: MARK-10, OTHER 2V, OTHER 4V, OFF*

```
OVERLD : MARK - 10
ESC    -  +  ENTR
```

#### 4.6.2 Compression and Tension Overload Settings (COMP OVERLD and TEN OVERLD)

This setting corresponds to the percentage of force gauge full scale at which crosshead travel stops. For example, a setting of 80% for a 50 lbf capacity force gauge would stop crosshead travel when approximately 40 lbf is reached.

##### Note:

When the crosshead is moving in the UP direction, only the tension overload setting applies. When the crosshead is moving in the DOWN direction, only the compression overload setting applies.

*Default setting: 100%*

*Available settings: 20% - 100% (10% increments)*

```
COMP OVERLD : 100%
ESC    -  +  ENTR
```

Label	Description
+ or -	Increases or decreases the value.
ENTR	Returns to the Test Feature Setup menu
ESC	Exits the feature without saving changes

#### 4.7.1 Preload (PRELOAD)

This setting corresponds to the test stand's response to an initial load, referred to as a *preload*. The crosshead can stop and/or zero the travel display when the preload has been reached. This function is useful for applications such as spring testing, elongation testing, and tensile and compression testing of various materials. In effect, it establishes a reference point. It is also sometimes referred to as a *touch*.

##### Note:

Before the start of a preload sequence, the crosshead must be positioned at either the upper or lower **physical** limit switch.

*Default setting: OFF*

*Available settings: STOP, STOP/ZERO, ZERO/GO, OFF*

```

PRELOAD : ZERO , GO
ESC      -   +   ENTR
  
```

Label	Description
+ or –	Cycles through the available settings listed below:
STOP	Crosshead stops when preload has been reached
STOP, ZERO	Crosshead stops when preload has been reached, then zeroes the travel display
ZERO, GO	Travel display is zeroed when preload has been reached, crosshead does not stop
ENTR	Returns to the Test Feature Setup menu
ESC	Exits the feature without saving changes

#### 4.7.2 Preload Value (PRELD %FS)

This setting corresponds to preload value, defined as a percentage of the force gauge's full scale in lbf units. The test stand's response, as described in the previous section, occurs when this value has been reached.

##### Note:

In low force applications, consider test stand vibration and crosshead acceleration, as they can be significant enough to produce a force exceeding the preload value.

*Default setting: 1%*

*Available settings: 0 – 100%*

```

PRELD %FS : 01 . 0
ESC      -   +   ENTR
  
```

Label	Description
+ or –	Increases or decreases the value in increments of .1
ENTR	Returns to the Test Feature Setup menu
ESC	Exits the feature without saving changes

#### 4.8 Load Holding

This setting directs the test stand to dynamically adjust the crosshead position to maintain a programmed force. The force is programmed as a set point in a Series 5 or 7 gauge (refer to the user's guide for details). If the **CYCLING** option has been installed, loadholding will be active for the period of time as defined in the Upper Dwell and Lower Dwell settings. If **CYCLING** has not been installed, loadholding will continue indefinitely. Pressing **STOP** will end loadholding.

*Default setting: OFF*

*Available settings: ON, OFF*

```

LOAD HOLDING : ON
ESC      -   +   ENTR
  
```

Label	Description
+ or –	Cycles through the available settings
ENTR	Returns to the Test Feature Setup menu
ESC	Exits the feature without saving changes

#### 4.9.1 Break Detection

This setting directs the test stand to stop when a sample break has occurred. The test stand stops when the force has decreased to a specified percentage of peak.

*Default setting: OFF*

*Available settings: ON, OFF*

```
BREAK DETECT : ON
ESC      -   +   ENTR
```

Label	Description
+ or –	Cycles through the available settings
ENTR	Returns to the Test Feature Setup menu
ESC	Exits the feature without saving changes

#### 4.9.2 Break Detection Activation Threshold

This setting corresponds to the force threshold after which the break detection function is active. The threshold is provided to prevent false activation of the function during sample handling. The threshold is defined as a percentage of full scale of the force gauge. For example, for a 50 lbF capacity force gauge, a setting of 10% represents 5 lbF.

*Default setting: 10%*

*Available settings: 1% - 95% (1% increments)*

```
BRK THRESH : 80%
ESC      -   +   ENTR
```

Label	Description
+ or –	Increases or decreases the value.
ENTR	Returns to the Test Feature Setup menu
ESC	Exits the feature without saving changes

#### 4.9.3 Break Detection Percentage of Peak

This setting corresponds to the force trigger for break detection, defined as a percentage of peak force. For example: A sample is pulled until 50 lbF, then breaks. The break detection percentage setting is 60%. After the sample breaks, the force rapidly decreases to 30 lbF (60% of peak), and causes the test stand to stop.

*Default setting: 80%*

*Available settings: 1% - 95% (1% increments)*

```
BREAK % PEAK : 10
ESC      -   +   ENTR
```

Label	Description
+ or –	Increases or decreases the value.
ENTR	Returns to the Test Feature Setup menu
ESC	Exits the feature without saving changes

#### 4.10 Control Source (CONTROL)

This setting corresponds to the source of test stand control. The default value **CONSOLE** sets the test stand to accept commands only from the console (front panel). Any external commands received through the serial port are ignored, except those noted in the **Communication** section.

**PC** refers to external control via serial communication. If any features are changed on the front panel, these settings will be ignored, except for **Auto Return** or **Cycling**. If either of these features are turned on, PC control will be turned off.

*Default setting: CONSOLE*

*Available settings: CONSOLE, PC*

```
CONTROL : CONSOLE
ESC      -  +  ENTR
```

Label	Description
+ or –	Cycles through the available settings
ENTR	Returns to the Test Feature Setup menu
ESC	Exits the feature without saving changes

#### 4.11 Baud Rate (BAUD RATE)

This setting corresponds to the baud rate setting of the computer program controlling the test stand.

*Default setting: 115200*

*Available settings: 1200, 2400, 4800, 9600, 19200, 38400, 57600, 115200*

```
BAUD RATE : 115200
ESC      -  +  ENTR
```

Label	Description
+ or –	Cycles through the available settings
ENTR	Returns to the Test Feature Setup menu
ESC	Exits the feature without saving changes

#### 4.12 Stop Bits and Parity (STOP & PAR)

This corresponds to the stop bits and parity settings of the computer program controlling the stand.

*Default setting: 8-1n*

*Available settings:*

```
8-1E  8 data bits, 1 stop bit, even parity
8-1o  8 data bits, 1 stop bit, odd parity
8-1n  8 data bits, 1 stop bit, no parity
8-2n  8 data bits, 2 stop bits, no parity
7-1E  7 data bits, 1 stop bit, even parity
7-1o  7 data bits, 1 stop bit, odd parity
7-2E  7 data bits, 2 stop bits, even parity
7-2o  7 data bits, 2 stop bits, odd parity
7-2n  7 data bits, 2 stop bits, no parity
```

```

STOP & PAR : 8 - 1 n
ESC   -   +   ENTR

```

Label	Description
+ or -	Increases or decreases the value.
ENTR	Returns to the Test Feature Setup menu
ESC	Exits the feature without saving changes

#### 4.13 Units of Speed (UNITS)

This setting corresponds to units of speed measurement.

*Default setting: in/min*

*Available settings: in/min, mm/min*

```

UNITS :      i n / m i n
ESC   -   +   ENTR

```

Label	Description
+ or -	Cycles through the available settings
ENTR	Returns to the Test Feature Setup menu
ESC	Exits the feature without saving changes

#### 4.14 Programmable Button Function (KEYS)

Three button function modes are available:

- Maintained**  
 The crosshead will move continuously once the button has been pressed and held. Subsequently pressing **STOP** will stop crosshead motion.
- Momentary**  
 The crosshead will move only if the button is held down. Releasing the button will stop movement immediately.
- Auto**  
 Holding down the button for more than 0.5 seconds will enter momentary mode, at which time an audible indicator will sound and the LED indicator on the button pushed will be illuminated. A short tap on the button will operate the test stand in maintained mode. Pressing **STOP** during maintained mode will stop crosshead motion.

*Default setting: maintained*

*Available settings: maintained, momentary, auto*

```

KEYS : MAINTAINED
ESC   -   +   ENTR

```

Label	Description
+ or -	Cycles through the available settings
ENTR	Returns to the Test Feature Setup menu
ESC	Exits the feature without saving changes



#### 4.15 Return to Default Settings (DEFAULT SETTINGS)

This setting provides a quick return to factory settings, as follows:

SPEED:	<b>10 in/min</b>
UP SPEED:	<b>10 in/min</b>
DOWN SP:	<b>10 in/min</b>
AUTO RETURN:	<b>off</b>
CYCLING:	<b>0000 (off)</b>
HI LIMIT:	<b>+12.000 / +19.000</b>
LO LIMIT:	<b>-12.000 / -19.000</b>
OVERLD:	<b>off</b>
PRELOAD:	<b>off</b>
LOAD HOLDING:	<b>off</b>
BREAK DETECT:	<b>off</b>
CONTROL:	<b>CONSOLE</b>
BAUD RATE:	<b>115200</b>
STOP & PAR:	<b>8-1n</b>
UNITS:	<b>in/min</b>
KEYS:	<b>maintained</b>
PASSWORD:	<b>0000 (off)</b>

*Default setting: off*

*Available settings: off, on*

<b>DEFAULT ? :</b>	<b>NO</b>
<b>ESC - + ENTR</b>	

Label	Description
<b>+ or -</b>	Cycles through the available settings
<b>ENTR</b>	Returns to the Test Feature Setup menu
<b>ESC</b>	Exits the feature without saving changes

#### 4.16 Password (NEW PWORD)

If desired, a password can be set to prevent unwanted changes to test features. The password can be set to any number between 0000 and 9999. The default setting of 0000 indicates that the password is disabled, and that the user can freely enter the Test Feature Setup menu. If misplaced or forgotten, the password may be reset through a code activation process. Details on this may be found in the **Function Activation** section.

*Default setting: 0000 (off)*

*Available settings: 0000 – 9999*

<b>NEW PWORD</b>	<b>0 0 0 0</b>
<b>ESC - + ENTR</b>	

Label	Description
<b>+ or -</b>	Increases or decreases the value.
<b>ENTR</b>	Returns to the Test Feature Setup menu
<b>ESC</b>	Exits the feature without saving changes

## 5 OPERATING MODES

### 5.1 Mode Overview

The ESM301 can be operated in several modes, including combinations of these modes:

1. **Basic Mode**  
Manual control of crosshead motion.
2. **Auto Return Mode**  
Crosshead moves to a limit switch or force set point, travel distance, preload, or sample break (referred to as *soft limits*), whichever occurs first. Then, it reverses and moves at maximum speed to the other limit, whichever occurs first.
3. **Cycling Mode**  
Crosshead cycles between limits at the selected speed(s), and pauses at each limit or set point for a selected period of time.
4. **Preload Mode**  
Crosshead moves until the preload has been reached, and performs the action programmed in the setting. An auto-return, cycle/dwell time, or break detection sequence may follow.
5. **Load Holding Mode**  
Crosshead moves to a force set point, stops, then dynamically adjusts position to maintain the programmed force. An auto-return or cycle/dwell time sequence may follow.
6. **Break Detection**  
Crosshead stops when a sample break has been detected. An auto-return or cycle/dwell time sequence may follow.
7. **PC Mode**  
See **Communications** section.

The Operating Mode home screen appears as follows:

```
SPEED :      0 . 0 0
menu min max SET
```

If the travel indication option is installed, the screen appears as follows:

```
TRAVEL      SPEED
  ↓          ↓
1 . 2 7 5   0 . 0 0
menu min max SET
```

The item selected will be capitalized, as shown in the figure above. The **set** speed can be changed in Test Feature Setup. If enabled, the up and down speeds can be configured independently of each other (**UP SPEED** and **DN SPEED**). Otherwise, the **SPEED** setting corresponds to crosshead speed in both directions.

### 5.2 Menu Navigation

At power-up, the display will show the operation screen for whichever mode was used last. The display will appear as one of the following:

1. **Basic & Auto Return Modes** (*travel indication option not installed*):

```
SPEED :      0 . 0 0
menu min max SET
```

2. **Basic & Auto Return Modes** (*travel indication option installed*):

```
TRAVEL      SPEED
  ↓          ↓
1 . 2 7 5   0 . 0 0
menu min max SET
```

3. **Cycling Mode** (*travel indication option not installed*):

```
TRAVEL      CYCLES REMAINING
  ↓          ↓
CYCLES :    0 0 0 2 4
menu min max SET
```

**Note:**

The **min** and **max** keys will not appear when a password has been set.

4. **PC Mode**

Appears the same as in Basic and Auto Return modes.

Label	Description
<b>menu</b>	Enters Test Feature Setup
<b>min</b>	Sets speed to minimum speed. Will not appear when a password has been set.
<b>max</b>	Sets speed to maximum speed. Will not appear when a password has been set.
<b>set</b>	Sets speed to the programmed SPEED, UP SPEED, or DN SPEED setting

Pressing **menu** will enter Test Feature Setup. If a password has been programmed, the display will prompt the following:

```
PASSWORD      0 0 0 0
ESC    -    +    ENTR
```

The password is a four digit number. Press **+** or **-** to increment or decrement the number. Once the complete password has been entered, press **ENTR**. If correct, the display will enter the Test Feature Setup menu. If the password is incorrect, the display flashes "INCORRECT PASSWORD", and then reverts to Operating Mode.

5.3 **Basic Mode**

The crosshead moves upward when **UP** is pressed, and downward when **DOWN** is pressed. When the crosshead is in motion, an LED indicator on the button pushed will be illuminated. The **KEYS** setting controls how crosshead movement responds to the push of the **UP** and **DOWN** buttons. The three settings are:

- 1. Maintained (default)**  
The crosshead will move continuously once the button has been pressed. Subsequently pressing **STOP** will stop crosshead motion.
- 2. Momentary**  
The crosshead will move only if the button is pressed and held. Releasing the button will stop movement immediately.
- 3. Auto**  
Holding down the button for more than 0.5 seconds will enter **Momentary** mode, at which time an audible indicator will sound and the LED indicator on the button pushed will be illuminated. A short tap on the button will operate the test stand in **Maintained** mode. Pressing **STOP** during **Maintained** mode will stop crosshead motion. To resume the test, press **UP** or **DOWN** again.

Pressing **EMERGENCY STOP** will immediately stop crosshead motion in any mode. To release, rotate clockwise. To resume the test, press **UP** or **DOWN**.

Crosshead movement will take place until a limit has been reached. If the crosshead has stopped at a soft limit, the limit condition may be overridden by pressing and holding **UP** or **DOWN** for two seconds.

#### 5.3.1 Travel Indication

If installed, travel indication is displayed in the upper left corner of the display. The displayed units are the same as programmed in the **UNITS** feature. Indicated travel is a relative value. To zero the value, press and hold **STOP** for two seconds.

If the cable connecting the crosshead to the rear of the controller is unplugged, the position value will not change when the crosshead moves.

#### 5.3.2 Limit Switch Operation

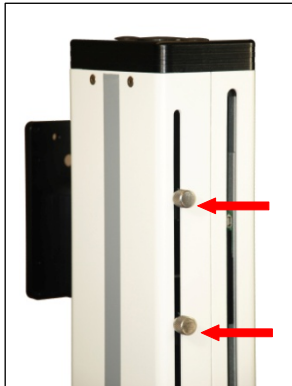

Limit switches allow the operator to set a location along the column at which point the crosshead will stop moving. Limit switches are located at the rear of the test stand column, as shown in the image to the left. Adjust the switches' positions by loosening, repositioning, and re-tightening the thumb screws. The thumb screws must be installed after unpacking. They are shipped separately to avoid damage in transit.

#### 5.3.3 Overload Protection

The 09-1162 cable is required for overload protection of a Mark-10 force gauge. If overload protection is installed and enabled, the crosshead will stop when the programmed percentage of full scale of the force gauge has been reached.

When overload protection is enabled, if the 09-1162 cable is disconnected, and/or if the force gauge is turned off, an error message will appear. Plug in the cable and/or turn on the force gauge to clear the message.

**Note:** When the crosshead is moving in the UP direction, only the tension overload setting is active. When the crosshead is moving in the DOWN direction, only the compression overload setting is active.

### 5.4 Auto Return Mode

In this mode the crosshead moves to whichever limit it encounters first and stops. Then, the crosshead returns at maximum speed to the other limit, whichever occurs first, and stops. The speed at which the crosshead travels is dictated by the **SPEED** setting or **UP SPEED** and **DN SPEED** settings (if the independent up and down speeds option is installed). Press **UP** or **DOWN** to initiate an Auto Return sequence.

The crosshead can be stopped at any time during an Auto Return sequence by pressing **STOP**. To resume the test, press **UP** or **DOWN**.

**Note:** If the crosshead has stopped at a soft limit, the limit condition may be overridden by pressing and holding **UP** or **DOWN** for two seconds.

### 5.5 Cycling Mode

This mode cycles the crosshead between limits, whichever occurs first. One cycle consists of the following steps:

1. Crosshead moves to a limit at the specified speed.
2. Crosshead stops for the specified amount of dwell time.
3. Crosshead reverses direction, returns to the other limit at the specified speed, and stops for the specified amount of dwell time.

A cycling sequence can be initiated from any position and can start in either direction. If the crosshead is at a limit, however, cycling can only be started in the opposite direction. To initiate a cycle sequence, press **UP** or **DOWN**. During a cycle sequence, a counter will be displayed, indicating the number of cycles remaining, as shown below:

```
CYCLES      0 0 0 2 4
menu min max SET
```

As in Basic Mode, the **min**, **max**, and **set** soft keys are active during crosshead movement.

When the cycling sequence and the crosshead has stopped at a *soft limit*, the limit condition may be overridden by pressing and holding **UP** or **DOWN**.

#### 5.5.1 Dwell time

Dwell time is the amount of time, in seconds, for which the crosshead stops at a limit during a cycle sequence. When the crosshead has reached a limit, a counter will be displayed, shown as follows:

```
DWELL :      0 0 0 1 . 5
menu min max SET
```

If the **DWELL U** and/or **DWELL L** settings are set to 0, the crosshead will immediately reverse direction upon reaching the corresponding limit, and no counter will be displayed.

The cycle sequence may be interrupted before it has been completed by pressing **STOP**. A soft key labeled **RESET** will appear as follows:

```
CYCLES :      0 0 0 2 4
                RESET
```

At this point, there are two options:

1. **Cancel the cycle sequence:**  
Press **RESET** to stop and reset the cycle sequence. The cycle counter will revert to the number of cycles originally programmed.
2. **Resume the cycle sequence:**  
Press **UP** or **DOWN** to resume.

Once the sequence has been completed, the screen will revert to the number of cycles programmed originally. To begin another cycle test, press **UP** or **DOWN**.

Travel indication and limit switch operation is the same as in Basic Mode.

### 5.5 Preload Mode

In this mode, the crosshead moves at the set speed (10 in/min [250 mm/min] maximum) until the programmed preload value has been reached. If moving in the up direction, a tension preload is required. If moving in the down direction, a compression preload is required. When the preload is reached, the sequence of events programmed in the **Preload** feature occurs. If the *ZERO, GO* setting is selected, and if the set speed is greater than 10 in/min, the crosshead speed will revert to this setting after the travel indicator is zeroed.

#### Note 1:

Before the start of a preload sequence, the crosshead must be positioned at either the upper or lower **physical** limit switch.

#### Note 2:

**Preload** and **Loadholding** cannot be enabled simultaneously.

### 5.6 Loadholding Mode

In this mode, the crosshead moves until the set point value programmed in the force gauge is reached. The crosshead then dynamically adjusts its position to maintain a programmed force. The force gauge's capacity should be as close as possible to the intended load, for best performance.

In the force gauge, **both** set points must be set. The upper set point refers to a force limit in the up (tension) direction. The lower set point refers to a force limit in the down (compression) direction. The opposite set point must be set to any value in the **opposite** measuring direction. For example, for a test requiring load holding at 10 lbF of compression force, set the upper set point to 30 lbF tension (as an example), and the lower set point to 10 lbF compression.

If the **CYCLING** option has been enabled, loadholding will be active for the period of time as defined in the **Dwell Time** settings. If **CYCLING** has not been enabled, load holding will continue indefinitely.

Before the start of a load holding sequence, the crosshead must be positioned at either the upper limit switch to begin compression loadholding or at the lower limit switch to begin tension loadholding.

An appropriate speed should be chosen for a given sample. Fine tuning may be necessary to ensure optimal crosshead dynamic behavior. Stiff samples require a lower test speed; softer samples can be tested at higher speeds. If the speed of approach is too high for a given sample stiffness, the crosshead may overshoot the set point value, requiring an adjustment sequence where the crosshead reverses, then moves again in the original direction multiple times before settling at the set point value. A high enough speed may cause this correction cycle to repeat indefinitely.

For softer samples the amplitude of oscillation will be smaller, but could still be present for the duration of the loadholding period. This is typical for samples which may relax, such as rubber, foam, etc. Lowering the test speed will reduce the oscillation.

For non-relaxing materials such as metal springs, the oscillation should stop shortly after the holding force is reached.

**Note:**  
**Preload** and **Load Holding** cannot be enabled simultaneously.

### 5.7 Break Detection Mode

In this mode, the crosshead will stop when a sample break has occurred. This action occurs when the force has decreased to a specified percentage of peak, as illustrated below:

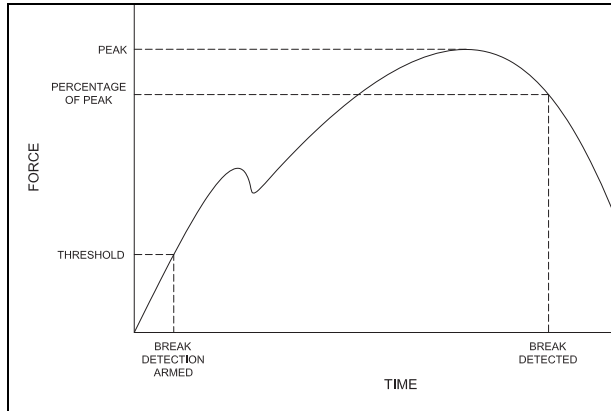

If enabled, an auto-return sequence or single-cycle sequence may follow break detection.

## 6 COMMUNICATION

### 6.1 Setup

The ESM301 can transmit force and travel (optional) data to a PC. The following settings are required for proper functioning of all test stand functions and data output:

**Force gauge / indicator (Series 5 / 7 only):**

- RS-232 communication
- 9,600 baud rate

**ESM301 test stand menu:**

- CONTROL: CONSOLE (this menu is only shown if the **PC Control** function is installed; **PC Control** is not required for data output)
- STOP & PAR (stop bits and parity): 8-1n (8 data bits, one stop bit, no parity)

**Connection cables:**

- Gauge / indicator to test stand: Part no. 09-1162
- Test stand to RS-232: Part no. 09-1056
- Optional RS-232 > USB converter: Part no. RSU100

If not using Mark-10 data collection software, ensure that the software's communication settings match. A number of data collection commands are available, highlighted in **blue** in the following section.

## 6.2 PC Control Mode

Motion control and data collection functions may be sent by an external device via user-developed applications. A list of supported ASCII commands is provided below.

**PC Control** is required for all commands, except those highlighted in **blue**.

Command	Description	Example
a	Request speed	
b	Set travel units to inches	
c	Enter cycle mode	
d	Move crosshead down	
e	Set speed Inch format: <b>eXX.XX</b> Two leading zeroes and two decimal places required.	e02.85 = 2.85 in/min
	Millimeter format: <b>eXXXX.X</b> Four leading zeroes and one decimal place required.	e0200.3 = 200.3 mm/min
f	Set cycles. Format: <b>fXXXX</b> (leading zeroes required)	f0500 = 500 cycles
g	Set lower travel limit Inch format: <b>g-XX.XXX</b> Negative sign (if applicable), two leading zeroes, and three decimal places required.	g-00.550 = -0.55 in g01.258 = 1.258 in
	Millimeter format: <b>g-XXX.XX</b> Negative sign (if applicable), three leading zeroes, and two decimal places required.	g-007.52 = -7.52 mm g010.70 = 10.7 mm
h	Set upper travel limit Inch format: <b>h-XX.XXX</b> Negative sign (if applicable), two leading zeroes, and three decimal places required.	h-00.550 = -0.55 in h01.258 = 1.258 in
	Millimeter format: <b>h-XXX.XX</b> Negative sign (if applicable), three leading zeroes, and two decimal places required.	h-007.52 = -7.52 mm h010.70 = 10.7 mm
i	Set travel units to millimeters	
j	Set crosshead speed to maximum speed	
k	Set crosshead speed to minimum speed	
l	Enter travel limit mode	
m	Enter manual mode	
<b>n</b>	<b>Transmit travel and force readings</b>	
o	Set crosshead speed to programmed speed	
p	Request stand status*	
q	Request number of cycles completed	
r	Request number of cycles set	
s	Stop crosshead	
t	Reset cycle counter to zero	
u	Move crosshead up	
v	Request upper travel limit	
w	Request lower travel limit	
<b>x</b>	<b>Request travel value</b>	
z	Reset travel to zero	

\* The transmission of ASCII "p" will return the stand status. The following are the return codes and their definitions:



	Command	Description
Crosshead status	U	Crosshead moving up
	D	Crosshead moving down
	S	Crosshead stopped
Operating mode	C	Cycle mode
	L	Limit mode
	M	Manual mode
Limit switch status	UL	Crosshead at upper limit
	DL	Crosshead at lower limit

Commands relating to Mark-10 instruments are **not** the same as indicated in their respective user's guides. A list of supported ASCII commands is provided below:

Command	Description
A	Displays current unit
F	Toggles between Normal and Data Collect modes
P	Steps through Normal mode, Tension Peak mode, and Compression Peak mode
R	<b>Zeroes the instrument (zeroes all modes)</b>
S	Sends current mode (Normal, Tension Peak, Compression Peak, or Data Collect)
U	Steps through units
X or ?	<b>Sends currently displayed reading</b>
Y	Enables RS-232 output and sends continuous data stream when in Data Collect mode
Z	<b>Zeroes the peak values</b>

Note that the ESM301 is compatible with legacy Nexygen™ TCD software, which also utilizes the above commands.

While in **PC Control**, if any features are changed on the front panel, these settings will be ignored, except if Auto Return or Cycling are turned on. If so, **PC Control** will be turned off automatically.

## 7 FUNCTION ACTIVATION

This menu displays the list of available functions and indicates which ones are installed, indicated by "ON" or "OFF". Those that are not installed can be installed in the field.

### 7.1 Accessing Function Activation Menu

While in Operating Mode, press and hold **STOP**, then press **menu** simultaneously, and release both buttons. The display will appear as follows:

```

CYCLING:      OFF
ESC  < - - >  ENTR

```

Label	Description
< -	Scrolls to the previous function
- >	Scrolls to the next function
ENTR	Selects the function
ESC	Exits Function Activation Menu

### 7.2 Activating Functions

Functions not originally purchased can be activated with an *authorization code*. To activate the function, scroll through the menu until the desired function is displayed, then press **ENTR**. If the function is already activated (indicated by "ON"), pressing **ENTR** has no effect. If the function is off, pressing **ENTR** will

generate a *request code* on the display, as shown below:

```
CYCLING: 0139027
ESC   +   -   ENTR
```

The *request code* must be supplied to Mark-10 or a distributor, who will then provide a corresponding *authorization code* to activate the function.

The process for entering the *authorization code* is as follows:

1. The first digit of the *request code* will be flashing. Press **+** to increment the digit. Pressing **+** when the number 9 is displayed will return to 0.
2. Press **->** to advance to subsequent digits, and change them in the same manner.
3. Press **ENTR** when complete. If an incorrect code is entered, the controller will return to the Function Activation Setup menu, without installing the function. If this happens the above process must be repeated.

The Function Activation Menu also includes a utility for disabling the password. Scroll through the functions until the following is displayed:

```
DISABLE PASSWORD
ESC  <-  ->  ENTR
```

Press **ENTR** to generate the *request code*, then follow the *authorization code* procedure as indicated above.

### 7.3 Demo Mode

All ESM301 test stands are shipped in *Demo Mode*, which provides full functionality of all available functions for an evaluation period of 160 operating hours. When this period has expired, an additional 160 hours may be added via the *authorization code* procedure indicated above.

## 8 TROUBLESHOOTING

### 1. The ESM301 displays several error messages, as follows:

Error Message	Description
CHECK GAUGE	The force gauge is powered off, in a menu, or not connected to the stand controller. Message appears when overload protection is turned on. Ensure that the force gauge is set to 9,600 baud and RS-232 communication. 09-1162 interface cable must be used.
GAUGE COMM ERROR	The stand is attempting to move the crosshead up or down, but it cannot establish communication with the force gauge. The communication settings in the force gauge are not correct or the gauge is in a menu. Ensure that the force gauge is set to 9,600 baud and RS-232 communication. 09-1162 interface cable must be used.
GAUGE OVERLOAD	The programmed overload percentage of the force gauge's full scale has been reached. Immediately reduce the force or adjust the overload settings.
M5 1.7+ REQD	A Series 5 or 7 force gauge with firmware version 1.7 or later is required for proper operation of the selected functions in the stand.

To clear any of the above errors, press **STOP**. The amber light in the **STOP** button will be blinking when the error message is displayed.

### 2. The crosshead will move only in one direction, or not at all.

Possible causes:

1. Ensure all cables are plugged in properly.
2. Ensure that the force value has not exceeded the overload limits configured in the stand.
3. Ensure that force gauge set points have been configured properly.

### 3. The travel display value does not change when the crosshead moves.

Check to make sure the encoder cable is plugged in properly.

### 4. Certain menu items are no longer displayed.

All test stand functions are temporarily enabled for 160 hours of operation in *Demo Mode*. When demo mode has expired, any functions (and their associated menus) not originally purchased will no longer be available.

## 9 MAINTENANCE AND SERVICE

The ESM301 should be operated in a dry and clean area. Under these circumstances only a few periodic maintenance operations are required:

### 9.1 Acme screw lubrication – twice per year



1. Remove the right column cover by loosening the screws, as shown above.
2. Using a brush, apply a small amount of general purpose lithium grease to the lead screw.
3. Cycle the crosshead up and down several times until the newly applied grease has been spread evenly over the length of the screw. Re-install the column cover.

### 9.2 Check for loosened grips and attachments – daily

Check to ensure that the grips attached to the force gauge and base plate are firmly secured. Looseness could result in a potentially hazardous situation.

### 9.3 Check for loosened components – once per month

1. Remove the test sample from the test stand.
2. Turn off power to the test stand and disconnect the power cord. Attempt to loosen subcomponents of the test stand (ex. fasteners, brackets, etc). All components should be firmly attached. If any looseness is detected, stop using the test stand and contact Mark-10 or a distributor for instructions.

### 10 SPECIFICATIONS

Load capacity:	
< 24 in [610 mm]/min:	300 lbF [1.5 kN]
> 24 in [610 mm]/min:	200 lbF [1 kN]
Standard speed range:	0.5 – 13 in/min [13 – 330 mm/min]
Optional speed range:	0.02 – 45 in/min [0.5 – 1,100 mm/min]
Maximum travel:	
ESM301:	11.5 in [292 mm]
ESM301L:	18.0 in [457 mm]
Speed setting accuracy:	±0.2%
Speed variation with load:	±0% [Stepper motor driven]
Travel accuracy:	±0.002 in [0.05 mm]
Travel resolution:	0.001 in / 0.02 mm
Limit switch repeatability:	0.001 in [0.03 mm]
Power:	Universal input 80-240 VAC, 50/60 Hz
Fuse type:	1.2 A, 250V, 3AG, SLO BLO
Weight (without options):	ESM301: 34 lb [15.4 kg] ESM301L: 39.5 lb [23.7 kg]
Environmental Conditions:	40 - 100°F [5 - 40°C], max. 96% humidity, non-condensating

### 11 DIMENSIONS

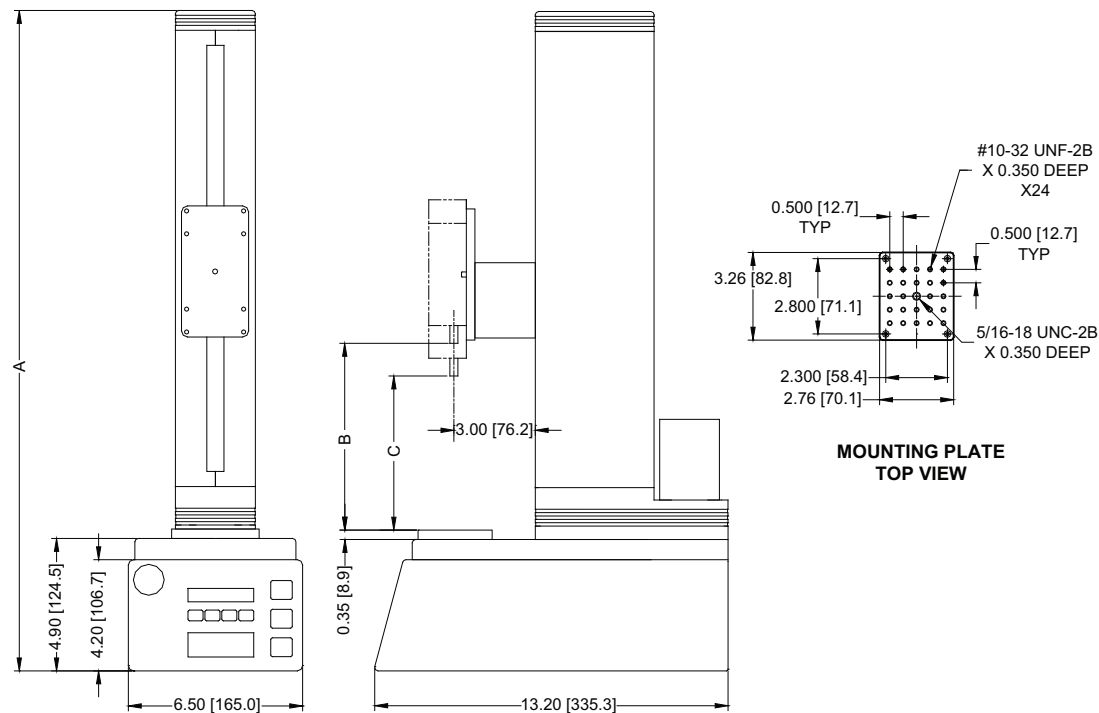

Model	A	B (Series 3/2)	C (Series 7/5/4)
ESM301	24.5 [622]	3.5 - 15.0 [89 - 381]	2.3 - 13.8 [58 - 351]
ESM301L	31.5 [800]	3.5 - 21.5 [89 - 546]	2.3 - 20.3 [58 - 516]



*Mark-10 Corporation has been an innovator in the force and torque measurement fields since 1979. We strive to achieve 100% customer satisfaction through excellence in product design, manufacturing and customer support. In addition to our standard line of products we can provide modifications and custom designs for OEM applications. Our engineering team is eager to satisfy any special requirements. Please contact us for further information or suggestions for improvement.*



*Force and torque measurement engineered better*

**Mark-10 Corporation**

11 Dixon Avenue  
Copiague, NY 11726 USA  
1-888-MARK-TEN  
Tel: 631-842-9200  
Fax: 631-842-9201  
Internet: [www.mark-10.com](http://www.mark-10.com)  
E-mail: [info@mark-10.com](mailto:info@mark-10.com)