



These adapters provide a commonly accepted industry method of attaching fixtures to load cells and test frames. They prevent grip rotation and allow for quick removal and installation.

Several thread sizes and variations are available to suit most common test frames, load cells, grips, and force gauges. Eye ends and adapters are available individually or as kits.

◀ Eye end adapter is shown with a wedge grip and motorized test stand.

Load Cell / Test Frame Configuration

Force Gauge Configuration

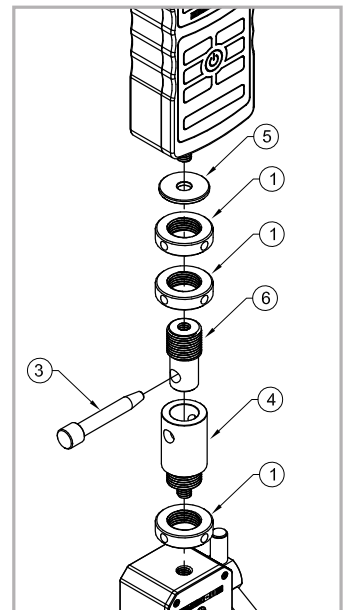
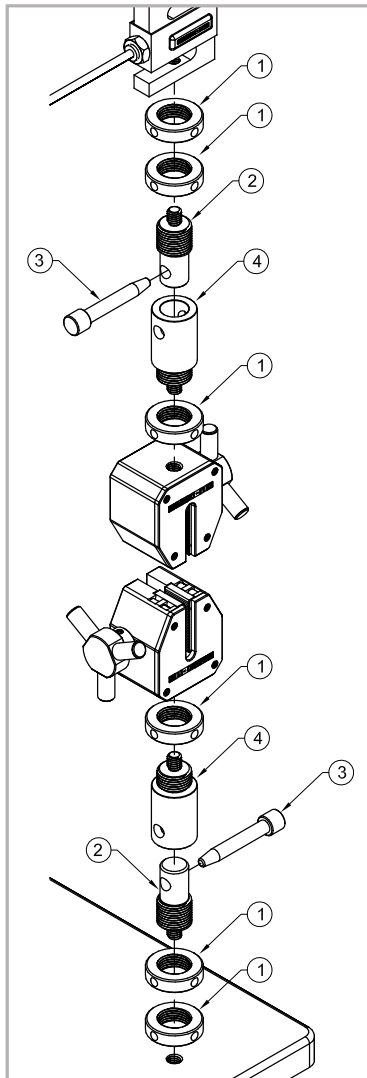

Item No.	Part No.	Description
1	G1079	Lock ring, 3/4-16
2	G1081	Eye end, #10-32M
	G1081-1	Eye end, 5/16-18M
	G1081-2	Eye end, 1/2-20M
	G1081-3	Eye end, 1/4-28M
3	G1080	Anchor pin
4	G1083	Eye end adapter, #10-32M
	G1083-1	Eye end adapter, 5/16-18M
	G1083-2	Eye end adapter, 1/2-20M
5	G1084	Washer, 0.20 ID
	G1084-1	Washer, 0.32 ID
	G1084-2	Washer, 0.51 ID
6	G1082	Eye end, #10-32F
	G1082-1	Eye end, 5/16-18F
Not shown	G1088	Spanner wrench (see next page)

Kits

Base / Load Cell Adapter Kits

AC1047	AC1047-1	AC1047-2	AC1047-3	AC1047-4	Item No.	Part No.	Qty.
X				X	2	G1081	1
	X				2	G1081-1	1
		X			2	G1081-2	1
			X		2	G1081-3	1
X	X	X	X	X	3	G1080	1
X	X	X	X	X	1	G1079	2
				X	5	G1084	1

Grip Adapter Kits

AC1046	AC1046-1	AC1046-2	Item No.	Part No.	Qty.
X			4	G1083	1
	X		4	G1083-1	1
		X	4	G1083-2	1
X	X	X	1	G1079	1

Force Gauge Adapter Kits

AC1045	AC1045-1	AC1045-2	Item No.	Part No.	Qty.
X			6	G1082	1
		X	2	G1081-2	1
	X		6	G1082-1	1
X			5	G1084	1
	X		5	G1084-1	1
X	X	X	1	G1079	2
X	X	X	3	G1080	1
		X	5	G1084-2	1



AC1047

AC1047-1

AC1047-2



AC1046

AC1046-1

AC1046-2



AC1045

AC1045-1

AC1045-2



AC1047-3

AC1047-4

Kit Compatibility Chart

Model No.	Description	Compatibility
AC1047	Test stand base adapter kit, #10-32M	- Test stand bases w/ #10-32 mounting
AC1047-1	Test stand base adapter kit, 5/16-18M	- Test stand bases w/ 5/16-18 mounting
AC1047-2	Test stand base / force sensor adapter kit, 1/2-20M	- Test stand bases w/ 1/2-20 mounting - Models MR01-300 / -500 / -750 / -1000 / -1500 / -2000 force sensors - Models MR07-300 / -500 / -750 / -1000 / -1500 / -2000 force sensors - Models FS06-300 / -500 force sensors
AC1047-3	Force sensor adapter kit, 1/4-28M	- Models MR01-50 / -100 / -200 force sensors - Models MR07-50 / -100 / -200 force sensors - Models FS06-50 / -100 / -200 force sensors
AC1047-4	Force sensor adapter, Series R03, #10-32M	Series R03 force sensors
AC1046	Grip adapter kit, #10-32M	Grips with #10-32 mounting
AC1046-1	Grip adapter kit, 5/16-18M	Grips with 5/16-18 mounting
AC1046-2	Grip adapter kit, 1/2-20M	Grips with 1/2-20 mounting
AC1045	Force gauge / force sensor adapter kit, #10-32F	- Force gauges up to 100 lbf capacity - Series FS05 force sensors up to 100 lbf
AC1045-1	Force gauge / force sensor adapter kit, 5/16-18F	- Force gauges with 200, 300, and 500 lbf capacities - Models FS05-200 / -300 / -500 force sensors
AC1045-2	Force gauge adapter kit, 1/2-20M	- Models M5-750 / -1000 / -1500 / -2000 force gauges

Individual Components

G1084-X Jam Washers

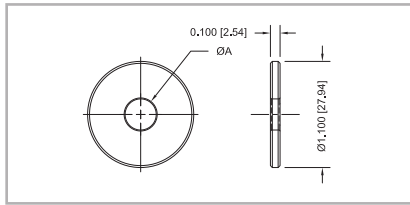

Part No.	ØA	Weight lb [kg]
G1084	0.20 [5.1]	0.03 [0.01]
G1084-1	0.32 [8.2]	0.03 [0.01]
G1084-2	0.51 [12.9]	0.03 [0.01]

G1079 Lock Ring

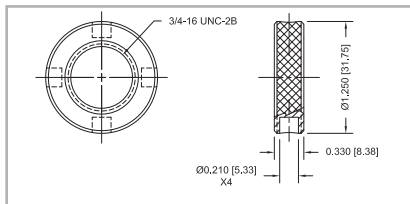

Weight lb [kg]
0.07 [0.03]

G1081-X Eye Ends

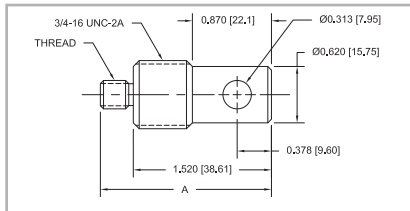

Part No.	A	Thread	Weight lb [kg]	Capacity lbF [kN]
G1081	1.82 [46.2]	#10-32	0.13 [0.06]	200 [1]
G1081-1	1.88 [47.8]	5/16-18	0.14 [0.06]	500 [2.5]
G1081-2	2.02 [51.3]	1/2-20	0.15 [0.07]	2,000 [10]
G1081-3	1.87 [47.5]	1/4-28	0.13 [0.06]	200 [1]

G1082-X Eye Ends

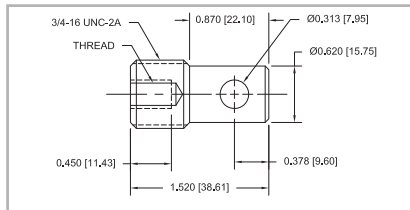

Part No.	Thread	Weight lb [kg]	Capacity lbF [kN]
G1082	#10-32	0.13 [0.06]	200 [1]
G1082-1	5/16-18	0.14 [0.05]	500 [2.5]

G1083-X Eye Ends

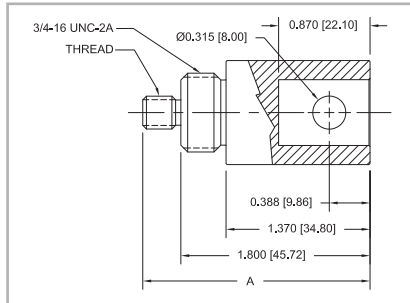

Part No.	A	Thread	Weight lb [kg]	Capacity lbF [kN]
G1083	2.10 [53.3]	#10-32	0.26 [0.12]	200 [1]
G1083-1	2.16 [54.9]	5/16-18	0.26 [0.12]	500 [2.5]
G1083-2	2.30 [58.4]	1/2-20	0.28 [0.13]	2,000 [10]

G1080 Anchor Pin

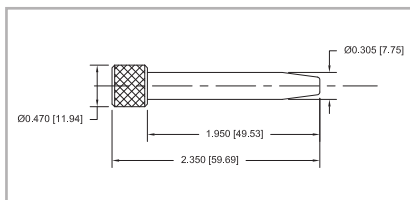

Weight lb [kg]
0.06 [0.03]

G1088 Spanner Wrench

